

Contents

SERVO 100 SERIES

Benefits	108
Type Designation	109
Mounting Example	110
Selection	111
Torque Ratings	113
Technical Data	114
Radial Load Slow Speed Shaft	115
Axial Load Slow Speed Shaft	116
Dimensions	118
Installation & Operation	126

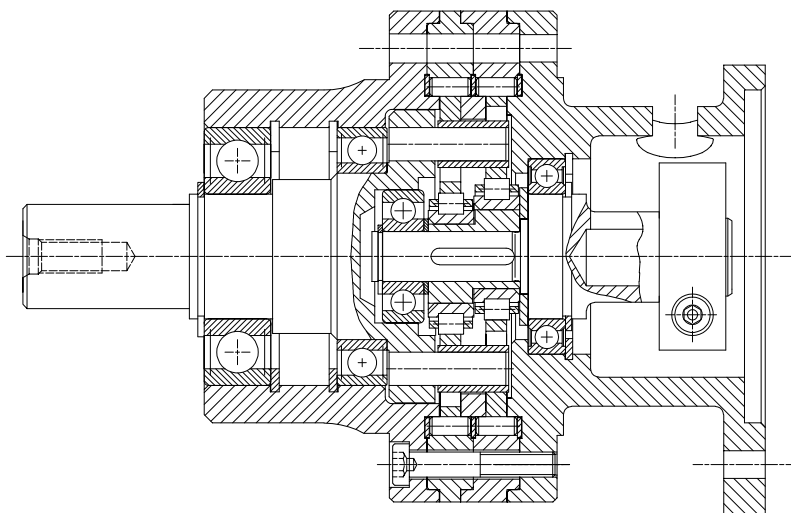

SERVO 100

SUMITOMO CYCLO EUROPE

Precision Series

Servo 100

Compact Low Backlash Gearboxes for Medium Precision Control

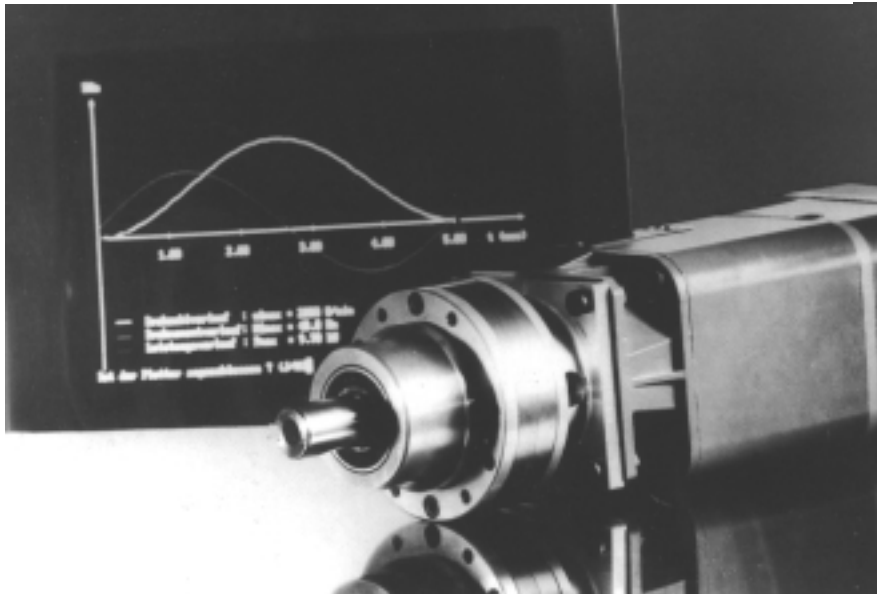

Low Backlash

The mechanical backlash is ≤ 3 arc min.

Compact Size

For similar torques, the outside diameter of the Series SERVO 100 is approx. 20% smaller than the previous CYCLO Servodrive range. The length is also reduced by approx. 30%.

When combined with a standard plug-in servomotor the overall length is approx. similar to that of the previous special closecoupled CYCLO Servodrive design.

Reduced Weight

The weight of the Series SERVO 100 is approx. 40% less than that of the previous CYCLO Servodrive range.

Standard AC/DC Servomotor combination

The Series SERVO 100 is designed to accept most AC/DC servomotors without modification. Motors are easily and positively connected by use of the hollow sleeve, key and clamp ring provided.

High Overload Capacity

Acceleration and braking torques can be considerably higher than the continuously rated motor torque. Reliable even in Emergency Stop situations.

XFCG	S	110	-	43	/	14	/	085
-------------	----------	------------	----------	-----------	----------	-----------	----------	------------

S = Special Design

Diameter of motor shaft

Flange Mounting
any mounting position life time guarantee

Pitch circle diameter of motor flange [e₁ in mm]

Size		Reduction Ratios
106	-	11/17/29/43
108	-	11/17/29/43/59
110	-	11/17/29/43/59/87
111	-	11/17/29/43/59/87

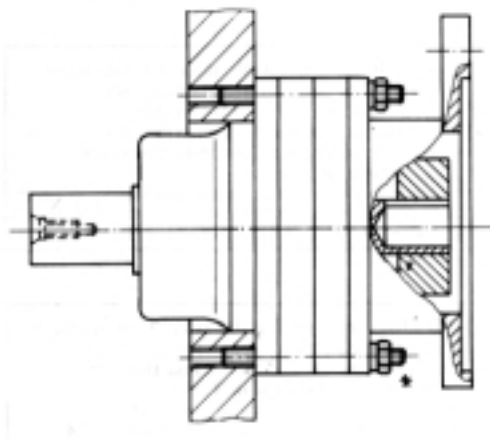

* Threaded Stud,
Washer & nut

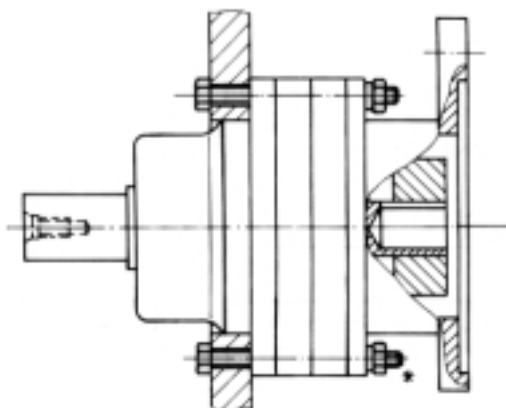

* Hexagonal Bolt,
Washer & nut

Selection of proper unit size is to be calculated as follows. When exceeding rating, please use larger size or change load specification.

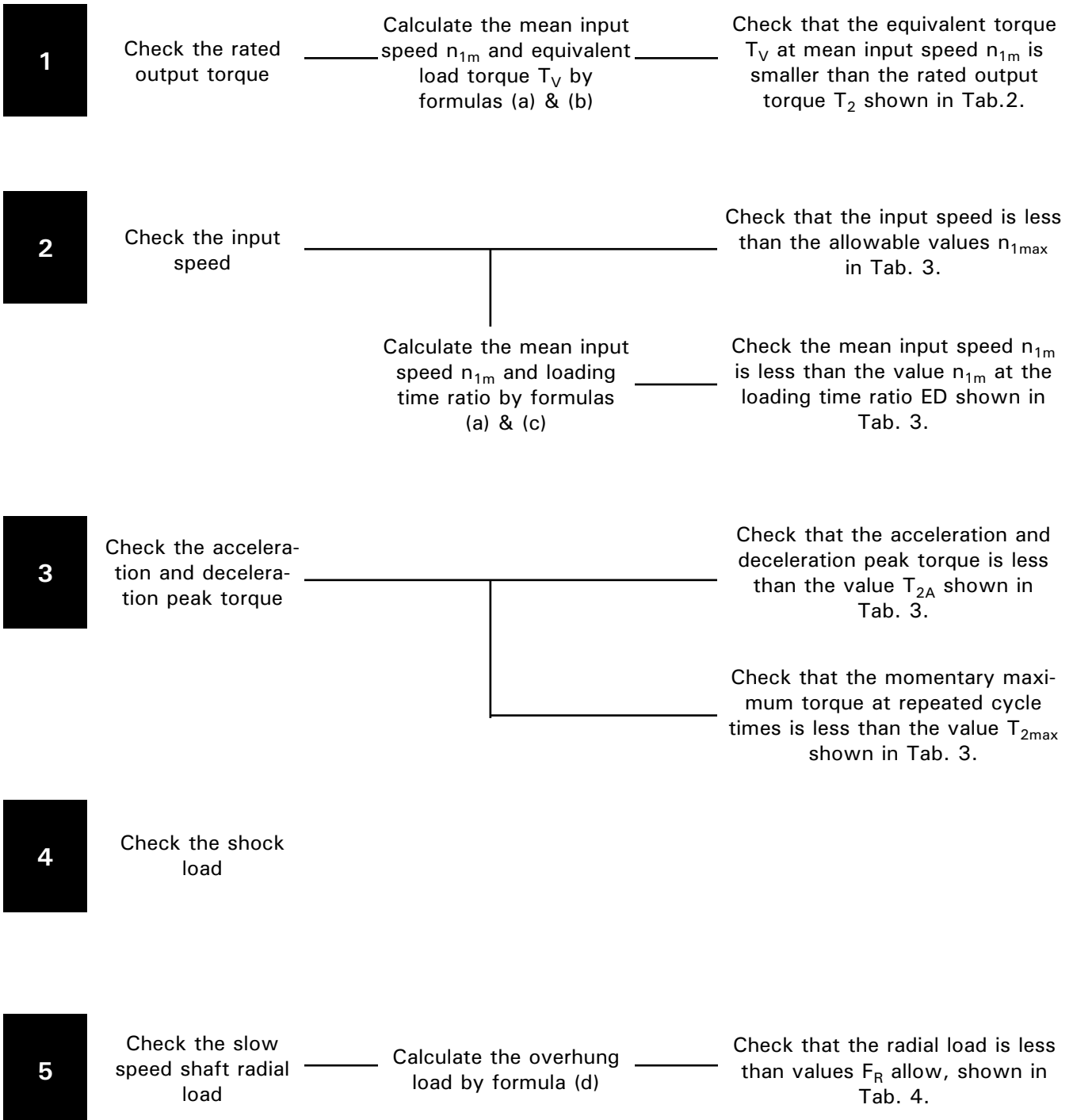

The equivalent torque is determined from the working cycle:

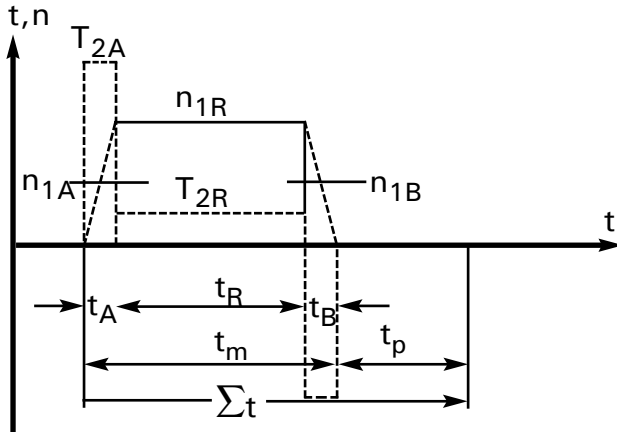

- T_{2A} = acceleration torque[Nm]
- T_{2R} = torque to overcome friction [Nm]
- T_{2B} = braking torque [Nm]
- n_{1A}, n_{1B} = mean input speed during acceleration and braking [rpm]
- n_{1R} = input speed with uniform movement [rpm]
- t_A, t_B = time for acceleration and braking [sec]
- t_R = duration of uniform movement [sec]
- t_m = duration of the movement phase of a working cycle [sec]
- t_p = duration of pauses [sec]
- S_t = cycle time [sec]
- $F_R \leq F_{R \text{ allow.}}$ [N]
- T_v = equivalent torque [Nm]
- L_f = load location factor
- C_f = load connection factor
- d_o = pitch diameter of gear or pulley [mm]
- n_{2m} = mean output speed [rpm]

The mean input speed of the working cycle is:

$$n_{1m} = \frac{n_{1a} \times t_A + n_{1R} \times t_R + n_{1B} \times t_B}{t_m}$$

The equivalent torque of the working cycle is calculated as follows:

$$T_{2V} = \left(\frac{T_{2A}^3 \cdot t_A \cdot n_{1A} + T_{2R}^3 \cdot t_R \cdot n_{1R} + T_{2B}^3 \cdot t_B \cdot n_{1B}}{t_m \cdot n_{1m}} \right)^{1/3} \leq T_{2N}$$

Load time ratio ED % is calculated as follows:

$$ED\% = \frac{t_m}{(t_m + t_p)} \times 100 \quad \text{or} \quad \frac{(\Sigma t - t_p)}{\Sigma t} \times 100$$

The overhung load is calculated as follows:

$$F_R = \frac{2 \cdot 10^3 \cdot T_v \cdot L_f \cdot C_f}{d_o}$$

Single Reduction

n_{1m} = Mean input speed [rpm]
 T_2 = Rated output torque [Nm]
 i = Reduction ratio

Tab. 2

i	n_{1m} [min-1] [rpm] [t/mn]	Size			
		106	108	110	111
		T2 [Nm]	T2 [Nm]	T2 [Nm]	T2 [Nm]
11	6000	16***			
	4500	18*	45***		
	3000	20	50*	107**	245***
	1500	25	62	132	302*
	1000	25	70	150	341
	500	25	75	184	419
17	6000	16***			
	4500	18*	54***	144***	
	3000	20	61*	162**	382***
	1500	25	75	200	470*
	1000	25	75	200	500
	500	25	75	200	500
29	6000	16***			
	4500	18*	54***	144***	
	3000	20	61*	162**	382***
	1500	25	75	200	470*
	1000	25	75	200	500
	500	25	75	200	500
43	6000	16***			
	4500	18*	54***	144***	
	3000	20	61*	162**	382***
	1500	25	75	200	470*
	1000	25	75	200	500
	500	25	75	200	500
59	4500		54***	144***	
	3000		61*	162**	382***
	1500		75	200	470*
	1000		75	200	500
	500		75	200	500
87	4500			144***	
	3000			162**	382***
	1500			200	470*
	1000			200	500
	500			200	500

*40 %, ** 20 % ED /duty factor /***short time

- n_{1m} = mean input speed [rpm]
- n_{1max} = max input speed [rpm]
- T_{2max} = reduction ratio
- T_{2A} = max acceleration torque [Nm]
- i = reduction ratio
- J = mass moment of inertia input [kg cm²]

Tab. 3

size	I	n _{1max.} [min ⁻¹] [rpm] [t/m _n]	n _{1m} [min ⁻¹] [rpm] [t/m _n]			T _{2A} [Nm]	T _{2max} [Nm]	J ** [kg cm ²]	backlash	stiffness at N _m [Nm/min]	weight ** [kg]
			duty factor								
			20%	40%	100%						
106	11	7300	5790	4600	3410	38	50	0,15	± 25	1,5	1,2
	17	7500	5970	4740	3510	38	50	0,14		1,6	
	29	8000	6340	5040	3730	38	50	0,14		2,6	
	43	8200	6520	5170	3830	38	50	0,14		2,8	
108	11	5200	4170	3310	2450	75	150	1,3	± 75	5,0	4,3
	17	5400	4290	3410	2520	110	150	1,3		5,4	
	29	5700	4560	3620	2680	110	150	1,2		8,8	
	43	5900	4700	3730	2760	110	150	1,2		9,0	
	59	6000	4820	3820	2830	110	150	1,2		10,0	
110	11	4300	3420	2720	2010	200	400	1,6	± 200	13,0	9,6
	17	4500	3560	2830	2090	300	400	1,5		15,0	
	29	4800	3810	3030	2240	300	400	1,4		20,0	
	43	4900	3930	3120	2310	300	400	1,4		22,0	
	59	5000	4010	3180	2360	300	400	1,4		23,0	
	87	5100	4060	3230	2390	300	400	1,4		25,0	
111	11	3000	2400	1900	1410	450	1000	3,5	± 500	27,0	18
	17	3100	2490	1980	1470	700	1000	3,2		36,0	
	29	3300	2660	2110	1560	700	1000	2,8		40,0	
	43	3400	2750	2180	1610	700	1000	2,7		42,0	
	59	3500	2800	2220	1640	700	1000	2,6		46,0	
	87	3600	2840	2260	1670	700	1000	2,6		50,0	

Approx. values (depending on motor shaft).
For explanation of terms see page 117.

When a gear or pulley is mounted on the slow speed shaft, a radial load is applied to the shaft. It is necessary to check the following formula to determine whether the shaft can accept the radial load.

Radial Load

$$F_R = \frac{2 \cdot 10^3 \cdot T_v \cdot L_f \cdot C_f}{d_o}$$

$$F_R \leq F_{R \text{ allow. [N]}}$$

T_v = equivalent torque [Nm]

L_f = load location factor

C_f = load connection factor

d_o = pitch diameter of gear or pulley [mm]

n_{2m} = mean output speed [rpm]

Tab. 4 F_R Allowable [N]

n_{2m} [min ⁻¹]	size			
	106	108	110	111
~10	1100	4100	9000	13000
15	1100	3900	9000	11000
20	1100	3500	8400	10000
25	1100	3200	7800	9800
30	1100	3000	7300	9200
35	1100	2800	6900	8700
40	1100	2700	6600	8300
50	1100	2500	6100	7600
60	1100	2300	5700	7100
80	1100	2100	5100	6400
100	1100	1900	4700	5900
125	1000	1800	4300	5400
150	970	1600	4100	5000
200	860	1500	3600	4500
250	790	1300	3600	4100
300	730	1200	3100	3800
400	650	1100	2800	
500	590	1000		
600	540			

Tab. 5 L_f

L mm	size			
	106	108	110	111
10	0,94	0,84		
15	1,06	0,92	0,84	
20	1,19	1,00	0,89	0,83
25	1,31	1,08	0,95	0,87
30		1,16	1,00	0,91
35		1,24	1,05	0,96
40		1,33	1,11	1,00
45			1,16	1,04
50			1,21	1,09
60			1,32	1,17
70				1,26
80				1,35
L mm	12,5	20,0	30,0	40,0

at $L_f = 1,0$

Tab. 6
Load correction factor C_f

	C_f
General Purpose Chain	1
Machine Gear or Pinion	1.25
Timing Belt	1.25

If the power is transmitted by bevel gear, spiral gear pinion or rigid coupling (for example in agitators), a complex axial/radial load is applied to the shaft. In such applications we suggest you consult SCE.

Slow speed shaftaxial load $F_{A \text{ allow}}$

Standard bearing without radial load

Axial Load F_A :

$$F_A \cdot C_f \leq F_{A \text{ allow}}$$

n _{2m} [min ⁻¹] [rpm] [t/m _n]	size			
	106	108	110	111
40	1000	1800	4500	6500
50	1000	1800	4500	6000
60	1000	1800	4500	5400
80	1000	1700	4100	4400
100	980	1500	3600	3800
125	840	1300	3100	3300
150	740	1100	2700	2900
200	610	960	2300	2300
250	520	820	2000	2000
300	450	720	1700	1700
400	370	580	1400	
500	310	480		
600	260			

Tab. 7 F_A Allowable

Rated output torque T_2

Rated output torque is the allowable mean load torque at mean input speed. Rated output torques for input speeds below 500 rpm are the same as for 500 rpm.

Input speed

Maximum input speed can be allowed up to the value $n_{1\max}$ shown in table 3, but allowable mean input speed n_{1m} is limited by loading time ratio ED.

Acceleration or deceleration peak torque

Table 3 shows allowable peak torque at normal start and stop T_{2A} .

Allowable momentary maximum torque

Table 3 shows allowable momentary maximum torque $T_{2\max}$ for emergency stop or heavy shock loading.

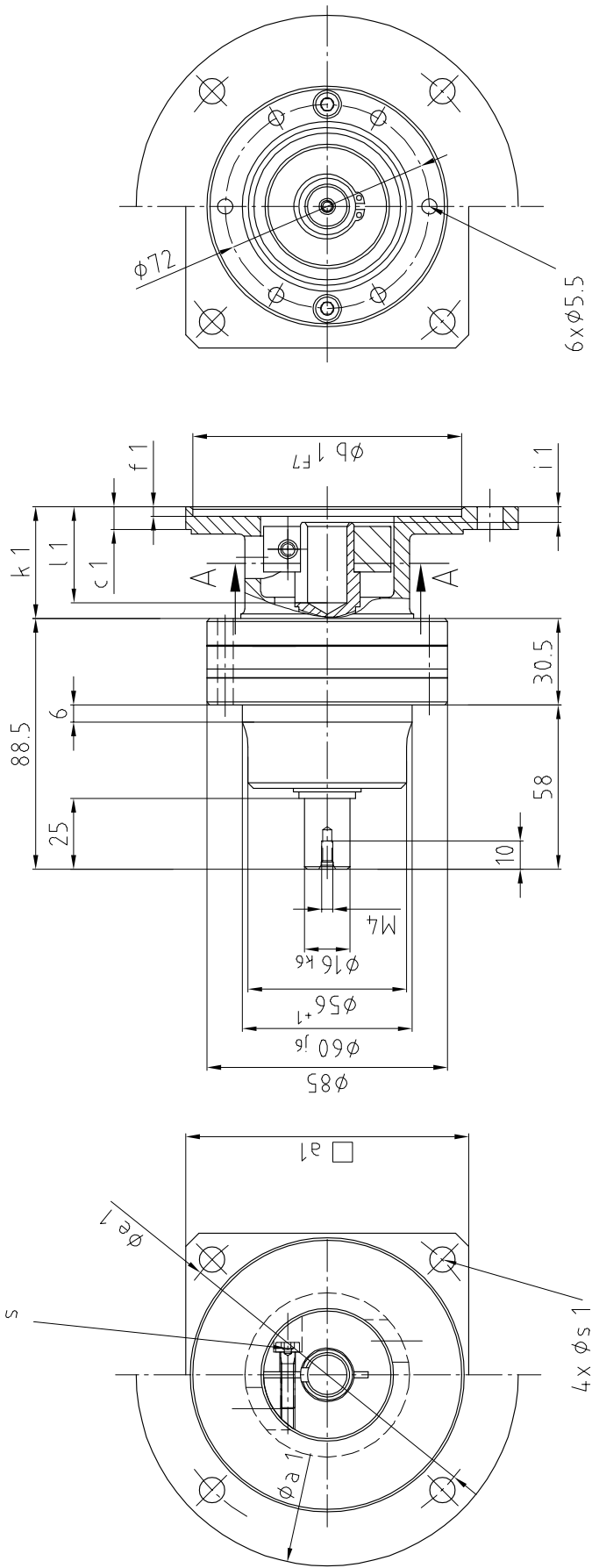

DIN 6885 Bl.1
AB 5x5x23

B - B

DIN 5480
W16x0.8x30x18x8h

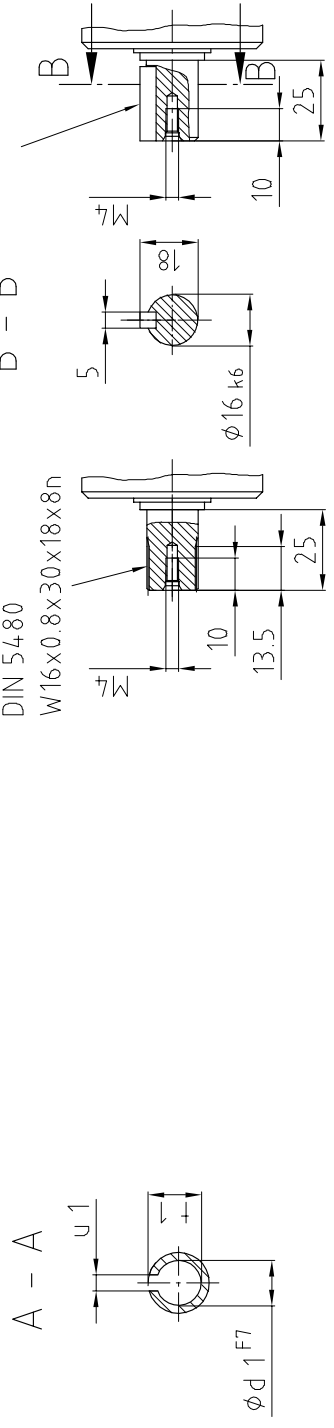

Optional designs
Tolerances acc. to DIN 7160

size type 106												
a ₁	b ₁ F ₇	c ₁	d ₁	e ₁	f ₁	i ₁	k ₁	l ₁	s	s ₁	t ₁	u ₁
70	60	8	11	75	3.5	5	39.5	34	4	5.5	12.5	4
70	60	8	14	75	3.5	5	39.5	34	4	5.5	16	5
80	70	8	14	85	3.5	5	39.5	34	4	6.6	16	5
140	75	8	12	88	3.5	5	39.5	34	4	5.5	13.5	4
115	80	8	11	100	3.5	5	39.5	34	4	6.6	12.5	4
92	80	8	14	100	3.5	5	39.5	34	4	6.6	16	5
100	95	8	14	115	3.5	5	39.5	34	4	9	16	5
130	60	8	16	75	3.5	7	51.5	46	4	9	18	5
150	95	8	14	115	3.5	7	51.5	46	4	6.6	16	5
140	95	8	14	115	3.5	7	51.5	46	4	9	16	5

* Dimensions of socket head screw in accordance with DIN 6912

Tab. 9

s* [mm]		4	5	6
Tightening torque	M _A [Nm]	5.5	9.6	23

size	a ₁	b ₁ F ₇	c ₁	d ₁	e ₁	f ₁	i ₁	k ₁	l ₁	s	s ₁	t ₁	u ₁
106	* as per customer's request, please consult SCE												

For high precision applications we recommend the use of motors with reduced concentricity in accordance with DIN 42955R.

Motors with standard flange concentricity and squareness tolerances according to DIN 42955 are acceptable for standard applications.

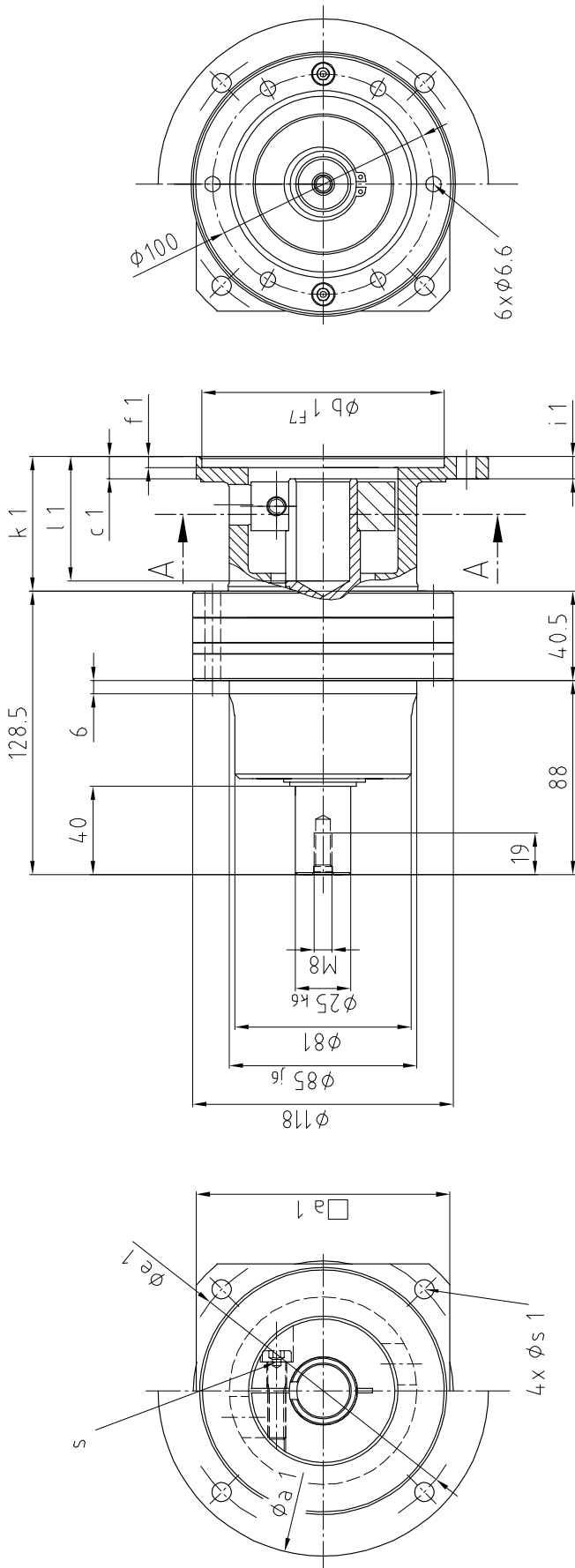

DIN 6885 Bl.1
AB 7x8x36

B - B

DIN 5480
W25x1.25x30x18x7m

Optional designs
Tolerances acc. to DIN 7160

size type 108												
a ₁	b ₁ F ₇	c ₁	d ₁	e ₁	f ₁	i ₁	k ₁	l ₁	s*	s ₁	t ₁	u ₁
80	70	10	14	85	5	7	50	40	4	6.6	16	5
80	70	10	19	85	5	7	50	40	5	6.6	21.5	6
92	80	10	14	100	5	7	50	40	4	6.6	16	5
92	80	10	19	100	5	7	50	40	5	6.6	21.5	6
150	95	10	14	115	5	7	50	40	4	6.6	16	5
165	95	10	14	115	5	7	50	40	4	6.6	16	5
100	95	10	14	115	5	7	50	40	4	9	16	5
100	95	10	19	115	5	7	50	40	5	9	21.5	6
115	95	10	19	130	5	7	50	40	5	9	21.5	6
146	110	10	19	130	5	7	50	40	5	9	21.5	6
185	130	10	19	165	5	7	50	40	5	11	21.5	6
140	95	10	14	115	5	9	61	55	4	9	16	5
160	110	10	16	130	5	9	61	55	4	11	18	5
115	110	10	24	130	5	9	61	55	6	9	27	8
185	130	10	24	165	5	9	61	55	6	11	27	8
145	130	10	24	165	5	9	61	55	6	11	27	8
242	130	10	24	165	5	9	61	55	6	9	27	8

* Dimensions of socket head screw in accordance with DIN 6912

Tab. 10

s* [mm]		4	5	6	
Tightening torque		M _A [Nm]	5.5	9.6	23

size	a ₁	b ₁ F ₇	c ₁	d ₁	e ₁	f ₁	i ₁	k ₁	l ₁	s	s ₁	t ₁	u ₁
108	* as per customer's request, please consult SCE												

For high precision applications we recommend the use of motors with reduced concentricity in accordance with DIN 42955R.

Motors with standard flange concentricity and squareness tolerances according to DIN 42955 are acceptable for standard applications.

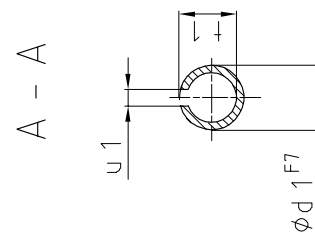
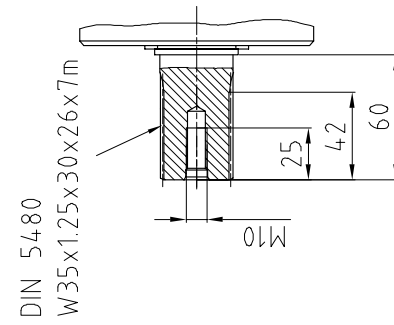
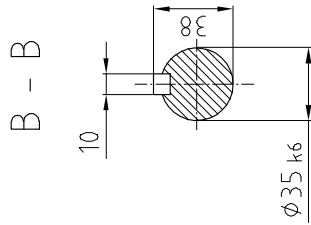
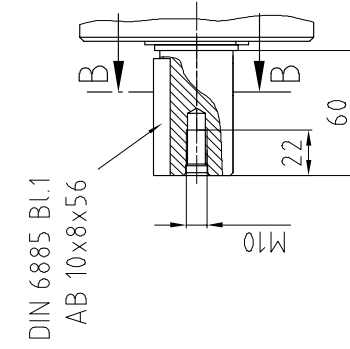
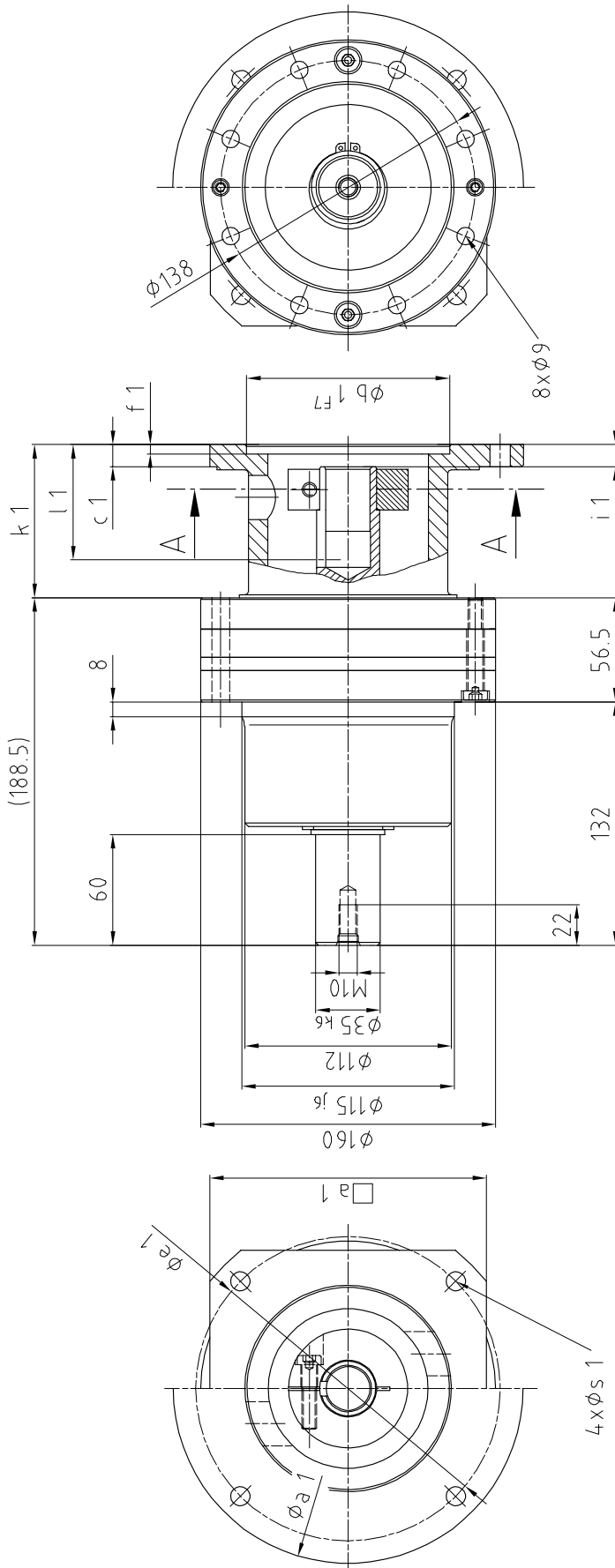

Optional designs
Tolerances acc. to DIN 7160

size type 110												
a ₁	b ₁ F ₇	c ₁	d ₁	e ₁	f ₁	i ₁	k ₁	l ₁	s*	s ₁	t ₁	u ₁
80	70	12	14	85	5	9	58	48	4	6.6	16	5
80	70	12	19	85	5	9	58	48	5	6.6	21.5	6
90	80	12	19	100	5	9	58	48	5	6.6	21.5	6
165	95	12	14	115	5	9	58	48	4	6.6	16	5
165	95	12	14	115	5	9	58	48	4	9	16	5
100	95	12	14	115	5	9	58	48	4	9	16	5
100	95	12	19	115	5	9	58	48	5	9	21.5	6
115	95	12	19	130	5	9	58	48	5	9	21.5	6
160	95	12	16	130	5	9	58	48	4	9	18	5
185	110	12	19	165	5	9	58	48	5	11	21.5	6
115	130	12	24	130	5	10	83	65	6	9	27	8
190	110	12	24	165	5	10	83	65	6	11	27	8
150	130	12	24	165	5	10	83	65	6	11	27	8
150	130	12	32	165	5	10	83	65	8	11	35	10
202	130	12	24	165	5	10	83	65	6	9	27	8
202	130	12	24	165	5	10	83	65	6	9	27	8
202	180	12	28	215	5	10	83	65	6	13.5	31	8

* Dimensions of socket head screw in accordance with DIN 6912

Tab. 12

s* [mm]		4	5	6	8
Tightening torque	M _A [Nm]	5.5	9.6	23	46

size	a ₁	b ₁ F ₇	c ₁	d ₁	e ₁	f ₁	i ₁	k ₁	l ₁	s	s ₁	t ₁	u ₁
110	* as per customer's request, please consult SCE												

For high precision applications we recommend the use of motors with reduced concentricity in accordance with DIN 42955R.

Motors with standard flange concentricity and squareness tolerances according to DIN 42955 are acceptable for standard applications.

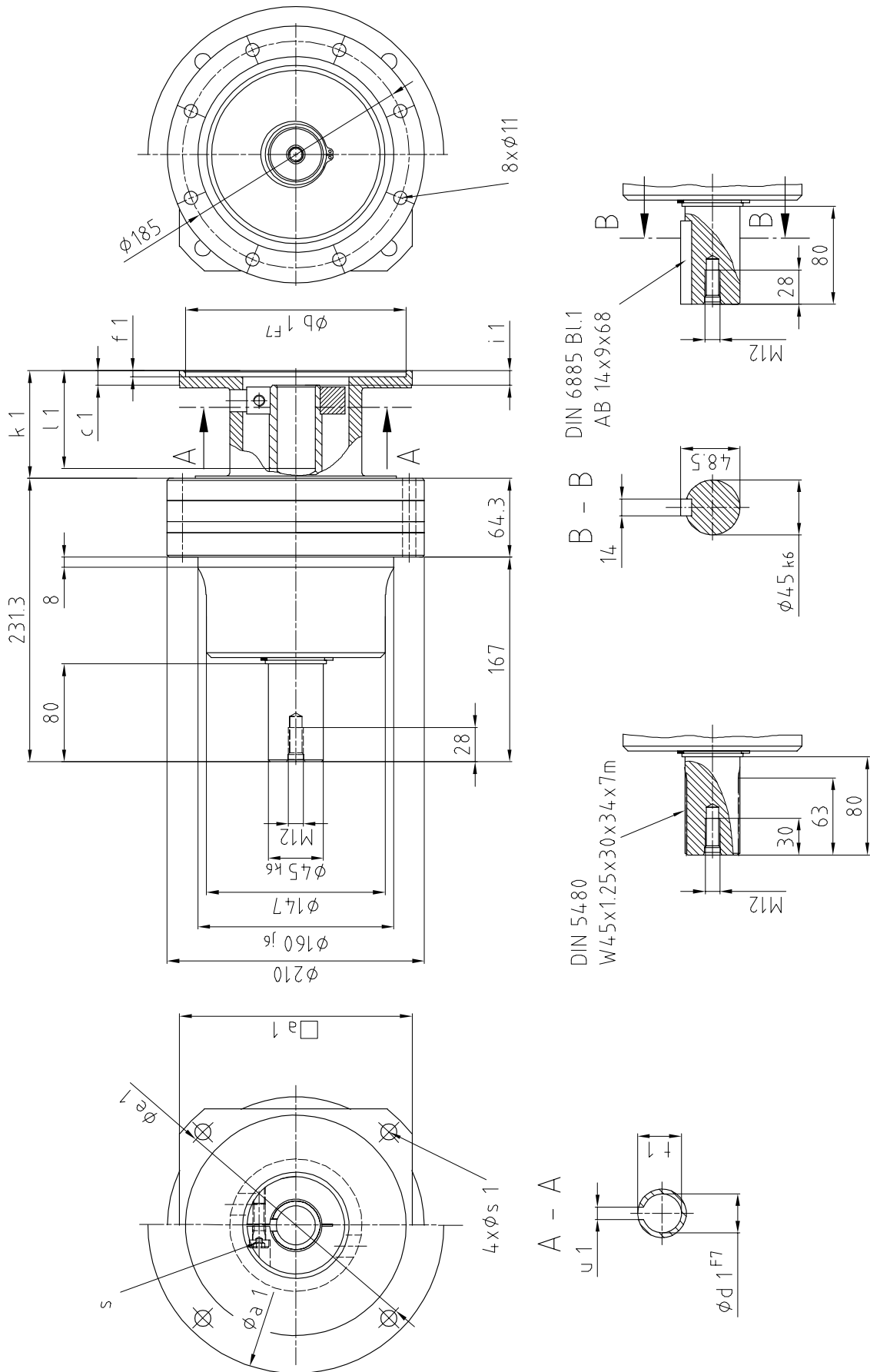

Optional designs
Tolerances acc. to DIN 7160

size type 111												
a ₁	b ₁ F ₇	c ₁	d ₁	e ₁	f ₁	i ₁	k ₁	l ₁	s*	s ₁	t ₁	u ₁
100	95	12	19	115	5	9	62	55	5	9	21.5	6
115	110	12	24	130	5	9	62	55	6	9	27	8
185	130	12	19	165	5	9	62	55	5	11	21.5	6
185	130	12	24	165	5	9	62	55	6	11	27	8
140	130	12	24	165	5	9	62	55	6	11	27	8
242	130	12	24	165	5	9	62	55	6	9	27	8
185	130	12	24	165	5	9	62	55	6	9	27	8
242	180	12	28	215	5	9	62	55	6	13.5	31	8
190	110	12	32	130	5	11	88	80	8	11	35	10
120	110	12	32	130	5	11	88	80	8	11	35	10
155	130	12	28	165	5	11	88	80	6	11	31	8
155	130	12	32	165	5	11	88	80	8	11	35	10
242	180	12	28	215	5	11	88	80	6	13.5	31	8
190	180	12	32	215	5	11	88	80	8	13.5	35	10

* Dimensions of socket head screw in accordance with DIN 6912

Tab. 13

s* [mm]		4	5	6	8
Tightening torque	M _A [Nm]	5.5	9.6	23	46

size	a ₁	b ₁ F ₇	c ₁	d ₁	e ₁	f ₁	i ₁	k ₁	l ₁	s	s ₁	t ₁	u ₁
111	* as per customer's request, please consult SCE												

For high precision applications we recommend the use of motors with reduced concentricity in accordance with DIN 42955R.

Motors with standard flange concentricity and squareness tolerances according to DIN 42955 are acceptable for standard applications.

1. Delivery Condition

CYCLO Speed Reducers leave the factory grease lubricated for life. The shafts are coated with rust preventative which can easily be removed with solvent. The solvent must not be allowed to come into contact with the seals.

Standard painting for all SCE gearmotors and reducers will correspond to Sumitomo Blue, which is resistant to weak acids as well as being weatherproof and *fade resistant*.

2. Mounting Motors

Before fitting the motor shaft into the hollow input sleeve of the CYCLO, ensure that both components are dry and free from grease. To complete the connection the socket head screw in the locking ring must be tightened to the recommended tightening torque. (The screw is grade 8.8).

3. Fitting couplings etc.

When fitting couplings, pinions, pulleys or sprockets etc. care must be taken not to apply excessive axial force or blows to the shaft, as this will damage the bearings. The component should be heated to approx 100°C or winched on using the tapped hole in the shaft end.

4. Installation

The speed Reducers are suitable for mounting in any position. They are designed for flange mounting and should be spigot located in FIG.2. All studs provided should be utilised to ensure the rated capacity of the unit can be transmitted.

5. Service

CYCLO Series SERVO Speed Reducers are grease lubricated for life. The lubricant needs changing only after 20,000 hours or 5 years operation, whichever is sooner.

6. Lubrication

Grease / Grease quantity.

size	106				108					110					111						
i	11	17	29	43	11	17	29	43	59	11	17	29	43	59	87	11	17	29	43	59	87
Grease Quantity	8	8	8	8	25	25	25	25	25	45	45	45	35	35	35	80	80	70	60	60	60
Grease	Shell Alvania RA																				